



**Subway Lighting  
Systems**

# Subway Lighting Systems

Designs are tailor-made to customer requirements and can be either Cornice Recessed or Surface mounted options. The cover is manufactured using 3mm mild steel which is powder coated White (other colour options available), secured as standard by 6 tri-head stainless steel anti-vandal fixings.

## Customised Designs



Through our Design Service, Signatures customers are offered advice on product selection.

With its own fabrication department, Signature are also able to manufacture alternative sizes and designs to meet the customers needs.

**Body** - Constructed from 3mm mild steel fabricated and galvanised after manufacture, each unit has 25mm conduit/cable entry ports in each end and slots to provide up to 10mm diameter fixing points.

**Window** - Comprising of two panels of either 4mm or 10mm with a 1mm protective cost effective barrier which protects the main window against attack such as graffiti.

**Gear Tray** - Polyester powder coated White gear tray, independently fused circuits with power factor correction as standard, suits either 2 x 18w, 2 x 24w or 2 x 36w compact fluorescent tubes.

(Other configurations available)

**Infill panels** - Standard panels 1000mm long, manufactured from 2mm mild steel powder coated White.

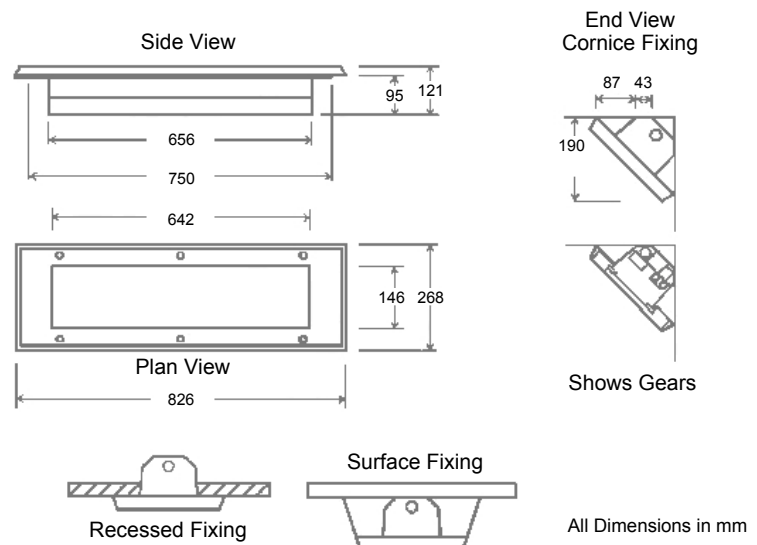

Signature® Limited



### Signature Ltd Head Office

Signature House  
51 Hainge Rd, Tivdale,  
Oldbury B69 2NY  
Tel: 0121 557 0234  
Fax: 0121 557 0995  
Email: sales@signatureltd.com  
Web: www.signatureltd.com

### Scottish Sales Office

Dee-Organ,  
Unit 4 Inchinnan Business Park,  
Newmains Avenue, Inchinnan,  
Renfrew, Renfrewshire PA4 9RR  
Tel: 0141 8125121  
Fax: 0141 8125125  
Web: www.dee-organ.co.uk

### John Wilkinson

10 Parkers Close  
Downton Business Centre  
Salisbury, Wiltshire, SP5 3RB  
Tel: 0870 777 2792  
Fax: 0870 777 2793  
Email: sales@johnwilkinsonltd.com  
Web: www.johnwilkinsonltd.com

### Post + Column Ltd

Road 4, Winsford Industrial Estate,  
Winsford, Cheshire,  
CW7 3RS  
Tel: 01606 550502  
Fax: 01606 550857  
Email: info@postandcolumn.co.uk  
Web: www.postandcolumn.co.uk

